

This document is our property for which we reserve all rights, including those relating to patents or registered designs. It must not be reproduced or used otherwise or made available to any third party without our prior permission in writing.

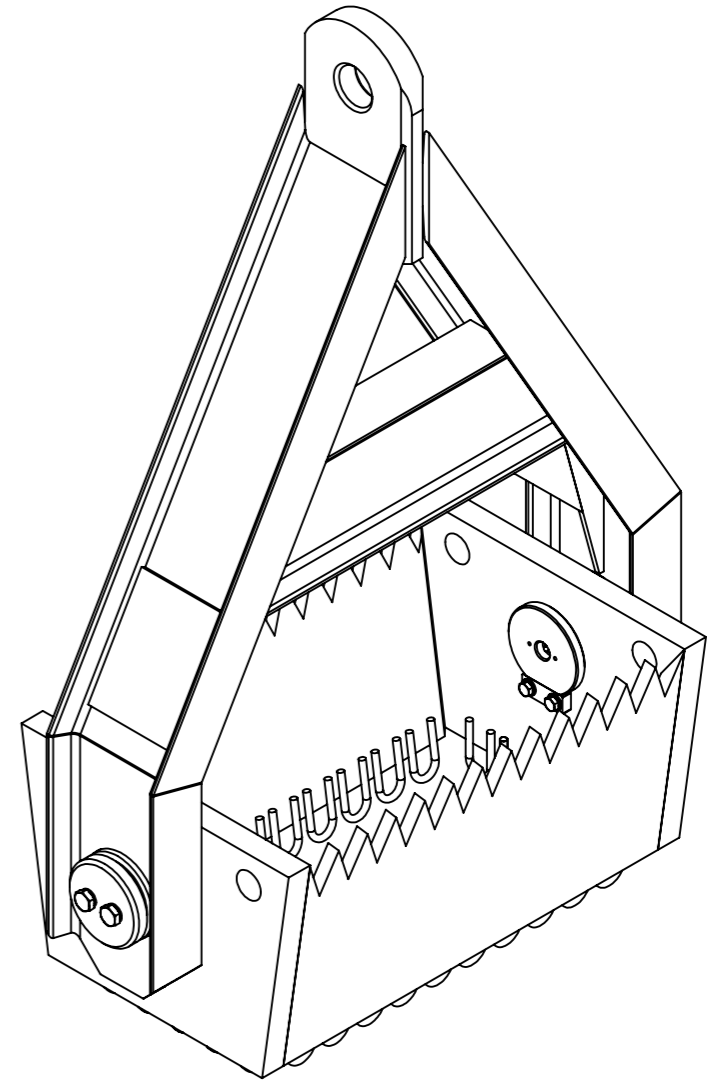
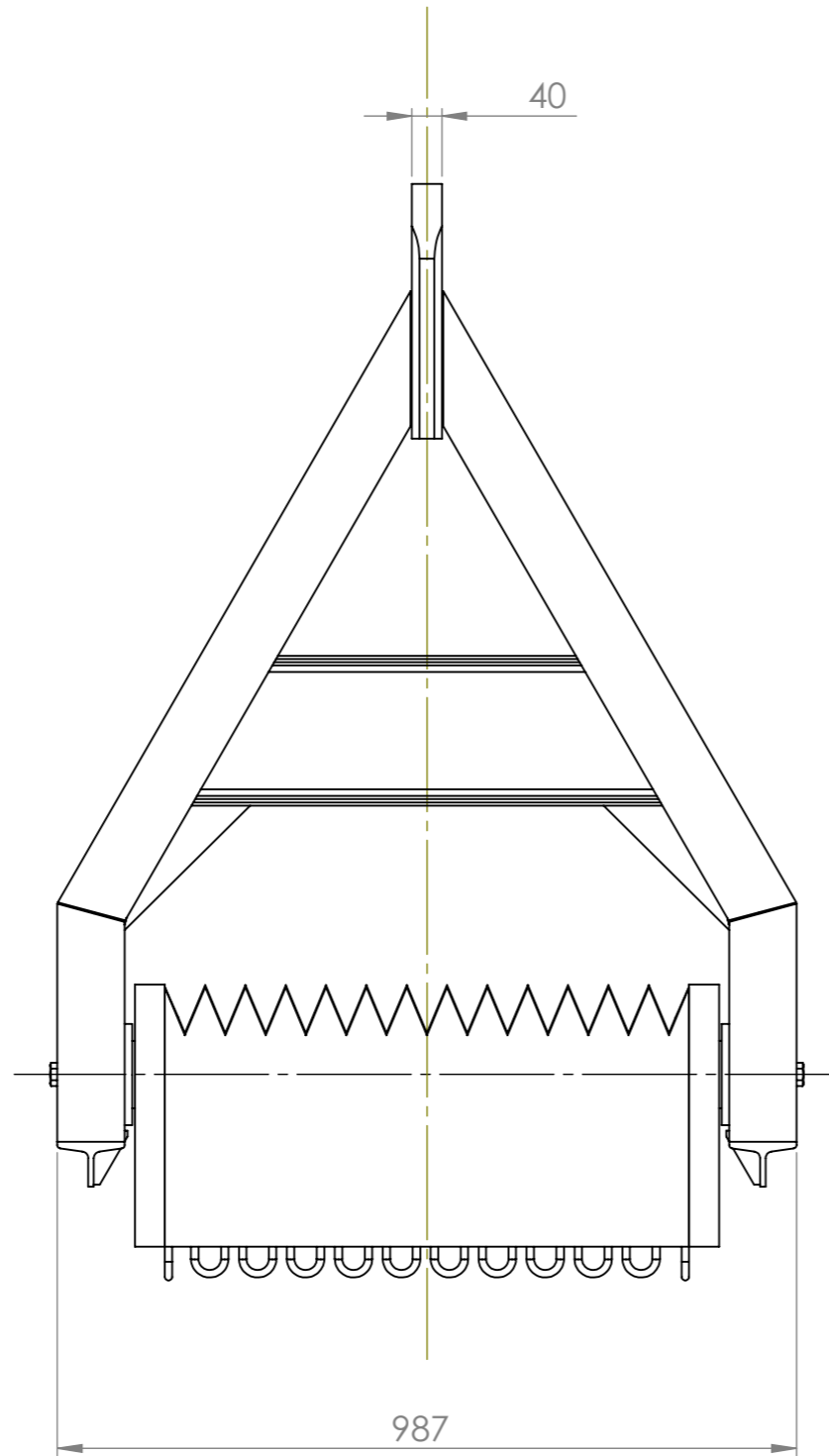
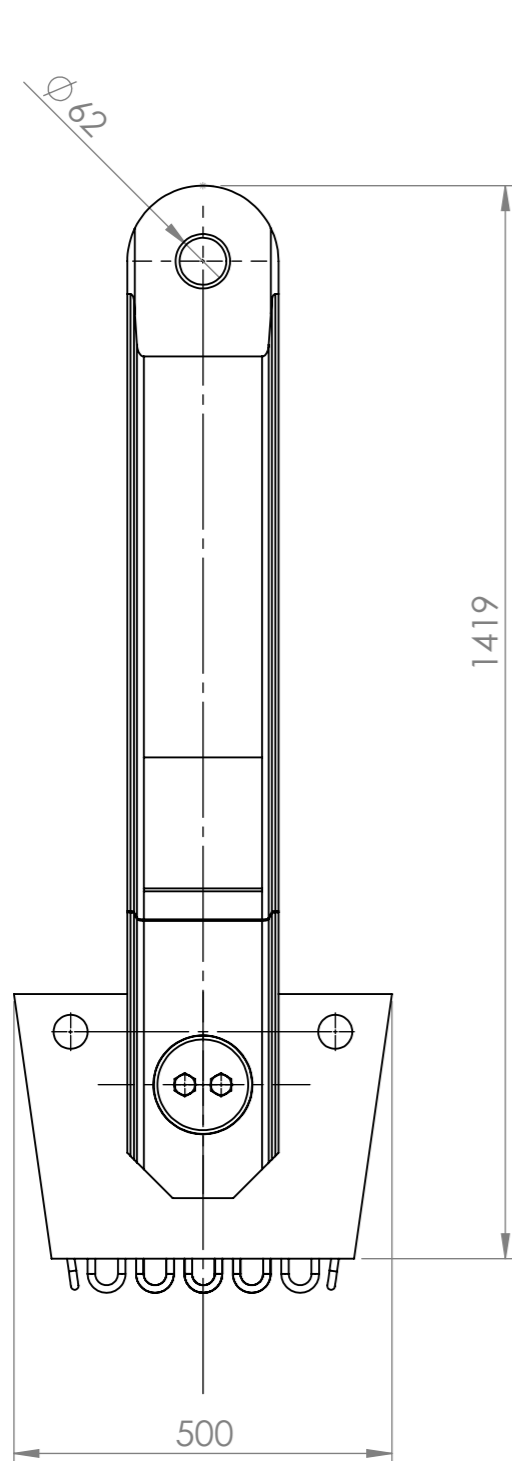

		General tolerances: ISO 2768-mK	Welding: ISO 13920	CAD-File for cutting:	ID. No.:
		Tolerances: ISO 8015	Preparation for coating ISO 8501-1:	MATERIAL:	
		Surface finish: ISO 1302	DEBUR AND BREAK SHARP EDGES Not allowed		
NAME	SIGNATURE	DATE	DRAWING NAME:		
DRAWN			<i>Скальная драга</i>		
CHK'D			DRAWING No:		
APPV'D			<i>ГК-ДР-0.5</i>		
<i>ГИКО</i>			DRAWING No:		A3
			<i>ГК-ДР-0.5</i>		WEIGHT: 330 kg
CUSTOMER:			SCALE: 1:20	SHEET 1 / 1	